

DESIGN AND ANALYSIS OF DIESEL FUELED SOLID OXIDE FUEL CELL SYSTEM ONBOARD SURFACE SHIP

**Yrd.Doç.Dr. M. Turhan ÇOBAN,
Dr.Y.Müh.Kd.Bnb. Cüneyt EZGİ**

Mechanical Engineering Department, Ege University, Izmir,
Turkey

Izmir Naval Shipyard, Izmir, Turkey

turhan.coban@ege.edu.tr, cuneytezgi2002@yahoo.com

Abstract

Solid oxide fuel cells (SOFCs) are a ceramic type of fuel cell operating at elevated temperatures. Fuel cells provide great potential for electric power generation on board surface ships. Today naval surface ships use F-76 diesel fuel. In this study, A 120 kW diesel-fueled solid oxide fuel cell system (SOFC) as an auxiliary engine on-board a surface ship was designed and thermodynamically analyzed. Fuel cell system was compared to diesel-electric generator set in a case surface ship.

SU ÜSTÜ GEMİDE DİZEL YAKITLI KATI OKSİTLİ YAKIT PİLİ SİSTEMİ TASARIMI VE ANALİZİ

Özetçe

Katı oksitli yakıt pilleri (SOFCs), yüksek sıcaklıklarda çalışan seramik tipte yakıt pilleridir. Yakıt pilleri, su üstü gemilerde elektrik gücü üretimi için büyük bir potansiyel sağlar. Günümüzde su üstü gemileri, F-76 dizel yakıtını kullanmaktadır. Bu çalışmada, bir su üstü gemide 120 kW güçte bir yardımcı makina olarak dizel yakıtlı katı oksitli yakıt pili sistemi tasarlanmış ve termodinamik analizi yapılmıştır. Analizde gerçek gazlara ait termodinamik özellikler, Java programı kullanılarak hesaplanmıştır. Yakıt pili sistemi, dizel-elektrik jeneratör grubu ile karşılaştırılmıştır.

Keywords: SOFC, Diesel fuel, Surface ship, Thermodynamic analysis, Diesel- electric generator set

Anahtar kelimeler: Katı oksitli yakıt pili, Dizel yakıt, Su üstü gemi, Termodinamik analiz, Dizel elektrik jeneratör grubu

1. INTRODUCTION

The more extreme weather situation the last decade, with floods, storms and drought, has lead to an increasing focus on global warming and the greenhouse gas emissions. The Kyoto protocol, which became operative the 16th of February 2005, sets targets to limit the amount of CO₂ and related greenhouse gas emissions. Other focal points for air emissions regulations are acidification and photochemical oxidation, which are results of release nitrogen oxides and sulphur oxides to the atmosphere. These three focal points for air emission influences the emission regulations for the shipping industry, and the regulations for all these emissions are getting stricter in the near future [1].

The exhaust from diesel engines is highly toxic. Among some of the most toxic substances emitted from diesels are hundreds of organic carbon compounds such as formaldehyde and polyaromatic hydrocarbons, many of which are carcinogens. The relationship between diesel exhaust and cancer has been well established in numerous epidemiological studies.

Furthermore, ship emissions contribute to numerous adverse environmental impacts. These include acidification, eutrophication of terrestrial and coastal ecosystems, damage to vegetation from ozone, increased corrosion to buildings and materials, deposition of toxic polycyclic organic matter and visibility impairment and regional haze.

Atmospheric emissions caused by the world's fleet of ships represent [2]: 2% of the global carbon dioxide emissions, 10-15% of global nitrous oxides (NO_x), 4-6% of global sulphur oxides (SO_x).

Today's conventional technology for auxiliary energy productions in ships has largely reached its potential for emission reductions. New and more energy efficient technologies are needed for a further decrease. One of those new technologies is fuel cell system.

Unit cells form the core of a fuel cell. These devices convert the chemical energy contained in a fuel electrochemically into electrical energy. The basic physical structure, or building block, of a fuel cell consists of an electrolyte layer in contact with an anode and a cathode on either side. A schematic representation of a unit cell with the reactant/product gases and the ion conduction flow directions through the cell is shown in Figure 1 [3].

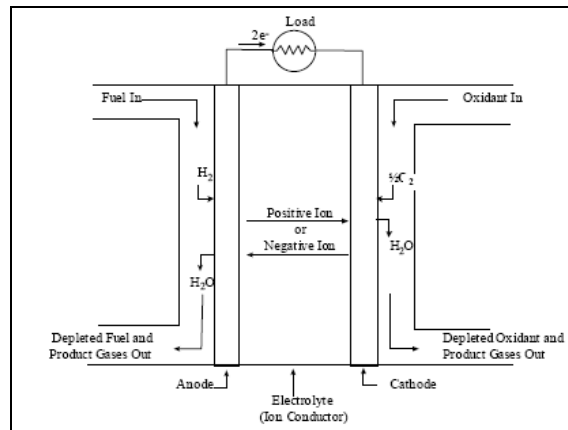

Fig.1. Schematic of an Individual Fuel Cell

2. SOLID OXIDE FUEL CELLS

A solid oxide fuel cell (SOFC) is an electrochemical device that converts chemical energy of a fuel and an oxidant gas (air) directly into electricity without irreversible oxidation. SOFCs are advanced electrochemical reactors operating at a high temperature. SOFCs are presently under development for a variety of electric power generation applications with high energy conversion efficiency.

When an external load is applied to the cell, oxygen is reduced at the porous air electrode to produce oxide ions. These ions migrate through the solid electrolyte to the fuel electrode, and they react with the fuel, H_2 or CO , to produce H_2O or CO_2 . Alternatively, a proton conducting solid electrolyte

*Design And Analysis Of Diesel Fueled Solid Oxide Fuel Cell System
Onboard Surface Ship*

can be used, where H_2 is oxidized to produce protons that subsequently react with oxygen to form water [4].

Electrochemical reactions which occurred on SOFC shown below and principal of operations are in Figure 2 [5].

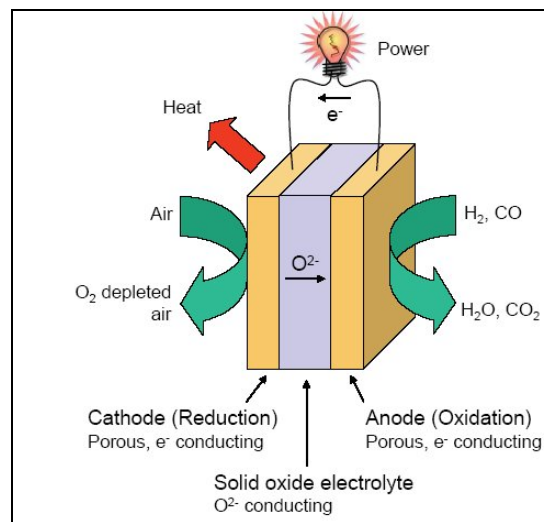
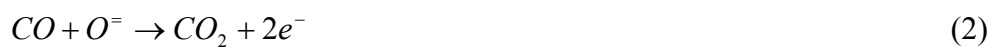

Fig.2. Electrochemical principle of the SOFC

The overall reactions for SOFC are presented below. The reactions occurring at the anode is:



The reaction occurring at the cathode is:



The overall reactions are:



SOFCs have an electrolyte that is a solid, non-porous metal oxide, usually Y_2O_3 -stabilized ZrO_2 . The cell operates at 600-1000 °C where ionic conduction by oxygen ions takes place. Typically, the anode is a Ni-ZrO₂ cermet and the cathode is Sr-doped LaMnO₃. The operating principle of a SOFC with an oxide ion conductor is schematically shown in Fig. 3 [6].

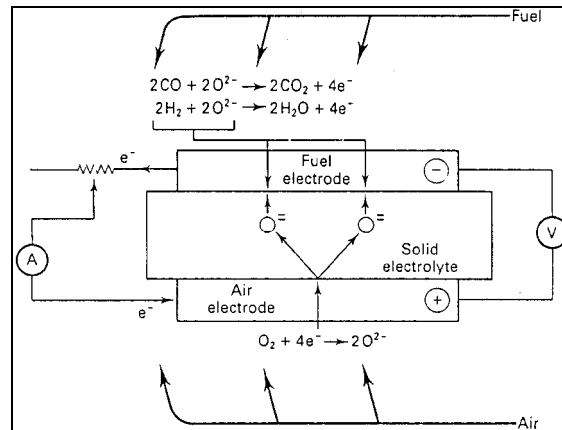

Fig.3. Principle of operation of SOFC

3. STORAGE OF DIESEL FUEL INSTEAD OF HYDROGEN

Hydrogen is an ideal fuel for fuel cells because of its high reactivity and zero emission characteristics. However, it is not feasible to store the hydrogen in surface ships because of the following reasons;

- Higher volume requirements
- High fuel storage cost and low energy storage efficiency
- Security problems

Diesel is one of the best hydrogen storage systems, because of its very high volumetric hydrogen density and gravimetric density [7]. This makes diesel reforming an attractive option for hydrogen production on-board surface ships. Diesel fuel is a complex mixture of many different hydrocarbons.

Power systems for the navies of NATO countries operate on NATO F-76 marine diesel fuel. This fuel is characterized as a 385 °C (max) end boiling point diesel fuel with up to 0.5 % sulfur by weight, by 2008 [8]. NATO F-76 standards are shown in Table 1 [8, 9, 10, 11].

Table 1
Properties of Logistic Fuel NATO F-76

Molecular formula (avg)	$C_{14.8}H_{26.9}$
Molecular weight	205
Density, at 15 °C, kg/m^3 , (max)	860
H/C ratio (molar)	1.82
Hydrogen content, wt, % (min)	12.5
Sulfur content (%) (max)	0.5
Net heating Value, kJ/kg	42,700
Final boiling point (°C) (max)	385

A characteristic formula for the simulation of diesel fuel is given in Table 2 [12]. Distillation characteristics are given in Table 3. This data is measured by our study group.

Table 2
Fuel mixture exhibiting similar characteristic to diesel fuel

Component	Mass fraction	Component	Mass fraction
n-Nonane	0.0122	n-Hexylbenzene	0.0041
n-Decane	0.0243	n-Heptylbenzene	0.0055
n-C11	0.0517	n-Octylbenzene	0.0058
n-C12	0.0912	n-Nonylbenzene	0.0059
n-C13	0.2007	n-Decylbenzene	0.0065
n-C14	0.1959	n-C11benzene	0.0030
n-C15	0.0980	n-C12benzene	0.0020
n-C16	0.0490	Naphthalene	0.0302
n-C17	0.0245	1-Methylnaphthalene	0.0654
n-C18	0.0122	1-Ethylnaphthalene	0.0433
n-C19	0.0061	1-Propylnaphthalene	0.0322
n-C20	0.0031	1-Butylnaphthalene	0.0215

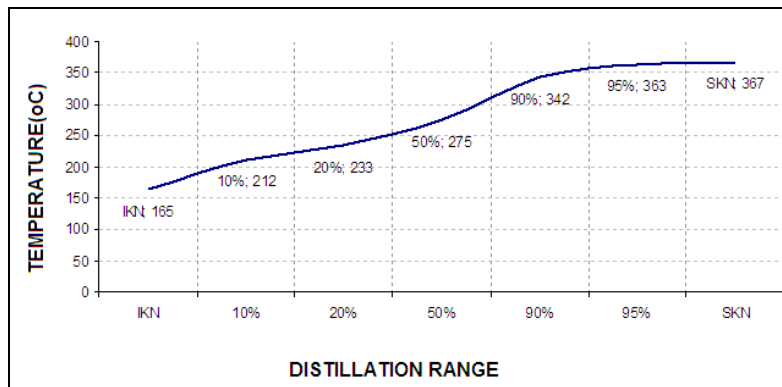

Fig. 4. A Typical of distillation curve of F-76 diesel fuel

4. GENERAL SYSTEM DESIGN AND THERMODYNAMIC ANALYSIS

In the case surface ship, SOFC system is designed to generate 120 kW electrical power. General system specifications are given at Table 3. System will be operated at atmospheric pressure. Operating parameters in fuel cell are presented in Table 4.

Table 3
General System Properties

Type of fuel cell	SOFC
Net power	120 kW
Fuel type	F-76 Diesel
Type of reformer	ATR
Pressure	Atmospheric Pressure +0.1 bar
Fuel storage	Liquid diesel tank

Table 4
Operating parameters

Operating voltage	0.8 V
Ideal voltage	0.9 V
Current density	0.4 A/cm ²
Electrolyte (10 μm)	8YSZ
Anode (1000 μm)	Ni-YSZ
Cathode (90 μm)	La _{0,7} Sr _{0,2} MnO ₃ (LSM)
Interconnectors	Stainless steel (X10CrAlSi18)

Diesel fuel stored in the fuel tank is preheated and boiled. After the desulfurization step, steam was added to the diesel before entering the reformer. Then, mixture is superheated and sent to autothermal reformer (ATR). The gases produced by fuel reformer, enter to anode side of the SOFC and come in to reaction with oxygen in the air which is sent to cathode. After for being used, gases coming from anode and cathode are sent to catalytic burner and gases produced from catalytic burner sent to high temperature heat exchanger to recover thermal energy. SOFC system flow diagram is given in Figure 5.

Ideal gas approach can be used for most of thermodynamic fuel cell system analysis. But, since process involves boiling of diesel fuel and heavy vapor representation by ideal gas equation carries some error Lee-Kessler equation that is modified Benedict–Webb-Rubin (BWR) is used to calculate thermodynamic properties.

It has been calculated thermodynamic specifications and provided stability of energy for every point (29 points) in the fuel cell system. Thermodynamic specifications are provided by using Java software language [13].

*Design And Analysis Of Diesel Fueled Solid Oxide Fuel Cell System
Onboard Surface Ship*

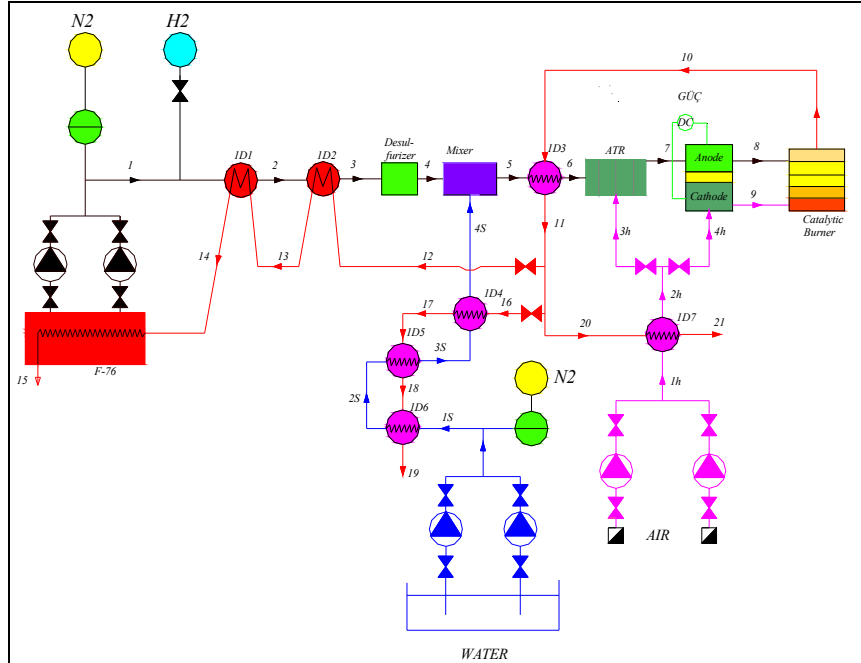
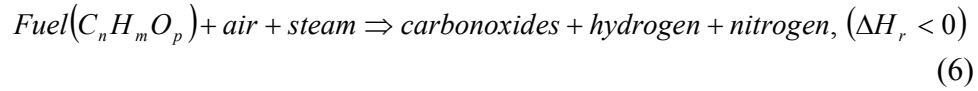

Fig.5. Diesel-fueled SOFC system

4.1. ATR

Autothermal reforming is a combination of partial oxidation and steam reforming. The fuel is mixed with steam and substoichiometric amounts of oxygen or air where the ratios of oxygen to carbon (O: C) and steam to carbon (S: C) are properly adjusted so that the partial combustion supplies the necessary heat for endothermic steam reforming. The auto thermal reformer consists of two zones; the thermal zone or the partial oxidation zone where partial combustion occurs and the heat generated is supplied to the subsequent endothermic steam reforming occurring in the catalytic zone. The reactions can either be run in a single reactor or in separated reactors that are in good thermal contact.

The autothermal reformers combine the heat effects of the PO and SR reactions by feeding the fuel, water, and air together into the reactor [13].



The ratio of amount of water given to reactor to amount of carbon in fuel is an important parameter for fuel reformer. This parameter calls as steam-carbon ratio. For a high fuel reforming efficiency steam to carbon ratio should be low, but in this reaction carbonization (formation of solid carbon) should be eliminated. This will require a relatively high steam to carbon ratios. In our design autothermal reaction temperature is taken as 700 °C which reaction enthalpy is zero and steam to carbon ratio is taken as 3.5.

$$\frac{(\text{Steam})_{mol}}{(\text{Carbon})_{mol}} = 3.5 \quad (7)$$

At the exhaust of autothermal fuel reformer, we will assume that mixture will reach to chemical equilibrium state. Chemical equilibrium calculation is carried out by using HSC Chemistry software. ATR exhaust gas composition (for 1 kmol diesel fuel) is given in Table 5.

Table 5
ATR exit gas composition

Reformate gas	kmol/kmol diesel
H ₂	26.086
CO	4.3922
N ₂	14.290
H ₂ O	31.413
CO ₂	8.5549

4.2. SOFC

SOFC is the main part of our energy exchanger system. In this system, air provided by a fan and then heated through a heat exchanger. Heated air is sent to cathode of the fuel cell and further heated and deoxygenated. The depleted air exhaust sends back to heat exchanger to heat incoming streams. Hydrogen rich fuel created in fuel reformer send the anode of fuel cell and electrical and thermal energy created in fuel cell.

It is impossible to use all fuel in real systems. Percentage of fuel used in fuel cell is called fuel changing rate. In our design fuel cell input temperature is 700 °C, fuel cell output temperature 850 °C and fuel reforming rate is assumed as % 90. At fuel cell anode side, for 1 kmol diesel fuel, input and output mol rates are given in Table 6.

Table 6
Inlet and exit of SOFC Anode

Gas	Inlet (kmol/kmol diesel)	Exit (kmol/kmol diesel)
H ₂ O	31,413	54,8904
H ₂	26,086	2,6086
N ₂	14,290	14,290
CO	4,3922	0,43922
CO ₂	8,5549	12,5078

4.3. Catalytic Burner

As mentioned in previous section, some of the fuel at fuel cell anode exhaust will remain unused. A catalytic burner is used to burn the remaining fuel from the anode side with the surplus air from the cathode side. Due to small percentages of fuel in the gas stream, it is difficult to burn in classical chambers. A catalytic burning system is suitable for relatively lean mixture combustion. Platinum in catalytic reactor will provide the required activation energy for combustion.

Gas inlet and exit mole percentages of catalytic combustion unit are given in Table 7. Catalytic burner exhaust is also exhaust of the fuel cell system. For this reason for comparison of exhaust emission values this mole percentages are also listed as g/kWh bases.

Table 7
Inlet and exit of burner

GAS	Inlet (kmol/kmol diesel)	Outlet (kmol/kmol diesel)	g/kWh
H ₂ O	54,8904	57,499	769
H ₂	2,6086	0	0
N ₂	164,766	164,766	3432
CO	0,43922	0	0
CO ₂	12,5078	12,947	423
O ₂	26,285	24,760	589

4.4. Heat Exchangers

Energy transferred by using gas which is provided from combustion chamber with fuel, water and heat exchanger. System includes totally 7 heat exchangers. It has been used shell and tube heat exchangers for gas-liquid fluids and compact heat exchangers (Figure 6) for gas-gas fluids. Austenitic stainless steel (UNS S30403) for 3 heat exchangers exposed to mid-degree temperature (up to 750 °C), nickel based alloy (UNS N06625) [15,16] for 4 heat exchangers exposed to high temperature (over 750 °C) has been choosed.

*Design And Analysis Of Diesel Fueled Solid Oxide Fuel Cell System
Onboard Surface Ship*

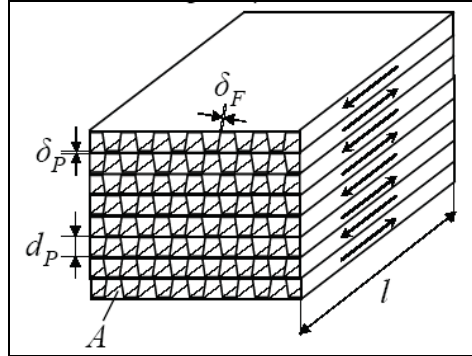

Fig.6. Compact Heat Exchanger Geometry

5. DIESEL ENGINE AS AUXILIARY POWER PRODUCING UNIT

The case surface ship has two engines for auxiliary power production, each with engine power of 72 kW. The characteristics for the engines are presented in the tables below.

Table 10
Specification of diesel engine

Engine power	72 kW
Type	2-stroke, 6-cylinder
Speed	1200 rpm
Type of fuel	MarineDiesel fuel
Mass	783 kg
Fuel consumption (at rated power)	20 kg/h

Table 11
Specification of generator

Generator power	60 kW
Nominal voltage	120 VDC
Nominal current	500 A
Nominal speed	1200 rpm
Mass	460 kg
Volume	2.444 m ³

5.1. Prevention of Air Pollution from Ships

International Maritime Organization (IMO), is to reduce ship based air pollution in maritime and provide for continual improvement, issued MARPOL 73/78/97 conventions. Appendix VI (Protocol 97) Prevention of Air Pollution from Ships, had entered in to force 19 May 2005. According to this Protocol, the vessels have to apply NO_x and SO_x standards of the Appendix VI. NO_x emission limits are set for diesel engines, which range from 9.8 to 17 g/kWh depending on the engine maximum operating speed, as shown in Table 12 [17, 18].

Table 12
MARPOL Annex VI NO_x emission limits

Engine speed (n) rpm	NO _x , g/kWh
$n < 130$ rpm	17.0
$130 \text{ rpm} \leq n < 2000$ rpm	$45 \cdot n^{-0.2}$
$n \geq 2000$ rpm	9.8

Annex VI regulations include a global cap of 4.5% (m/m) on sulfur content of fuel oil and calls on IMO to monitor the worldwide average sulfur content of fuel. Special fuel quality provisions exist for “SO_x Emission Control Areas”, where the sulfur content of fuel oil used on board

*Design And Analysis Of Diesel Fueled Solid Oxide Fuel Cell System
Onboard Surface Ship*

ships must not exceed 1.5%. Alternatively, ships must fit an exhaust gas cleaning system or use any other technological method to limit SOx emissions to ≤ 6 g/kWh (as SO₂ mass) [17, 18]. The air emission per functional unit, 1kWh, is calculated and is shown in Table 13.

Table 13
Air emission factors for case auxiliary diesel engine

Component	g/kWh
CO ₂	890
SO _x	0.75
NO _x	11.5
CO	0.5

6. RESULTS

In the ideal case of an electrochemical converter, such as a fuel cell, the change in Gibbs free energy, ΔG , of the reaction is available as useful electric energy at the temperature of the conversion. The ideal efficiency of a fuel cell, operating reversibly, is then

$$\eta_{ideal} = \frac{\Delta G}{\Delta H} = 77.03\% \quad (8)$$

The thermal efficiency of an actual fuel cell operating at a voltage of V_{cell} is 68.47%. The fuel processor efficiency based on lower (net) heating value (LHV) of component was determined using:

$$\eta_{fuelprocessor} = \frac{LHV \text{ of anode feed gas}}{LHV \text{ of reformer fuel}} \quad (9)$$

The gross efficiency, which combined the fuel cell, fuel processor was 58.19%.

$$\eta_{gross} = \varepsilon_{fuelcell} \varepsilon_{fuelprocessor} \quad (10)$$

$$\eta_{gross} = 68.47\% \times 85\% = 58.19\%$$

The net efficiency of SOFC system with F-76 diesel fuel, estimated as 55.28, included the effect of the parasitic energy load on the system required to power the pumps and blower. Total fuel consumption is 30 kg/h, for producing 120 kW electrical powers. For the case surface ship, to produce the same amount of power by existing 2 pieces diesel generator the consumption is total 40 kg/h. diesel fuel. With using solid oxide fuel cell system in place of diesel generator, fuel consumption will reduce 10 kg/h F-76 diesel fuel. Results of thermal analyze of fuel cell system is given in Table 9.

Table 9
Output conditions

Parameter	Value
Total electric power	120 kWe
Reformer type	ATR
Reformer S/C	3,5
Fuel cell inlet gases (% mol)	
Hydrogen (H ₂)	30,78
Carbon monoxide (CO)	5,18
Nitrogen (N ₂)	16,86
Water (H ₂ O)	37,07
Carbon dioxide (CO ₂)	10,10
Reformer efficiency,%	85,0
SOFC efficiency,%	68,47
Net efficiency,%	55,28
Total F-76 Diesel feed required, kg/h	30

*Design And Analysis Of Diesel Fueled Solid Oxide Fuel Cell System
Onboard Surface Ship*

Fig. 7 presents the amount of diesel fuel needed as a function of SOFC system power.

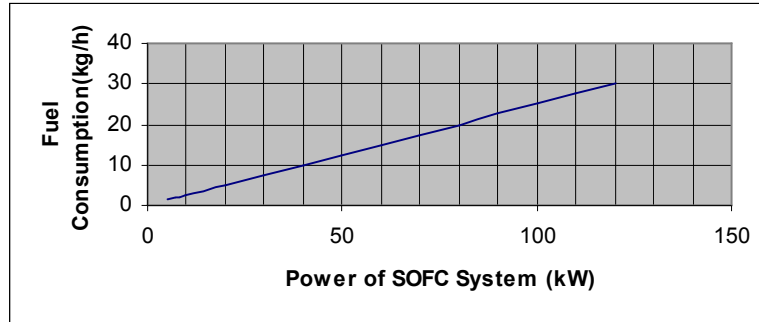

Fig.7. Consumption of marine diesel fuel

For production of 120 kW electric powers, it has been designed as in 170mmX170mm dimensions, total 1350 fuel cells, and 2 stacks. Each of them includes 75 serial plates which composed of 9 cells. It has found that SOFC system will be 520 kg and 2000 liter. 2 diesel generator sets are 2486 kg and 4888 liter. There is not any weight and place restriction for fuel cell stacks and on surface ship, and can be installed as modular.

SOFC system emits only 423 g CO₂/kWh, and 52,47% less than diesel auxiliary engine. In the case ship, diesel motor's NO_x emission is more than the limits of MARPOL Annex VI. (10,898 g/kWh NO_x, at n=1200 rpm).

Noise level in engine room of the case surface ship was measured 100 dB (A). Motional parts are only blower and pumps in SOFC system. Blower noise level is 70 dB (A). Furthermore in the SOFC system, the noise of the blower can be decreased to 50 dB (A), by insulating.

The case ship's service electric is direct current (DC). Therefore; we do not need inverter for changing the current to AC. Moreover, total installation cost of SOFC system was decreased and 5% efficiency drop is prevented by not using the inverter.

For comparison, the calculated electrical efficiency for F-76 diesel-fuelled fuel cell system based on steam reforming and PEM-fuel cells was 35–40%, depending on the current density of the fuel cell applied [18]. Their simulations were at lower operating temperatures.

7. CONCLUSIONS

A 120 kW diesel-fueled SOFC system as an auxiliary engine on-board a surface ship was designed and thermodynamically analyzed. Fuel cell system was compared to diesel- electric generator set in a case surface ship.

The most promising features of SOFC systems are high efficiencies, fuel flexibility and negligible harmful emissions like particulate matter, oxides of nitrogen, oxides of sulphur, unburned CO and hydrocarbons. With excellent emissions performance, SOFC system secures not only the IMO/MARPOL regulations but also assures more of what regulation needs. Noise scale is logarithmic, so a difference of 10 dB (A), make a significant difference to the human ear. Therefore, the noise in a cabin of a fuel cell powered ship is expected to be similar to that found in an office.

SOFCs have great potential to improve ship energy conversion systems. With SOFC system new, stricter environmental regulations can be observed. Furthermore, It provides minimized signatures for naval ships.

REFERENCES

- [1] Marte Reenaas, Solide oxide fuel cell combined with gas turbine versus diesel engine as auxiliary power producing unit onboard a passenger ferry, Norwegian university of science and technology, February 2005
- [2] Endresen.Q.,Sorgard.E.,SundetJ. K., Dalsoren S.B.,Berglen T.F.,Gravir G. And Isaksen I.S.A., Environmental impact of international sea transportation, accepted by the Journal of Geophysical Research, 2003
- [3] Fuel Cell Handbook (Seventh Edition), U.S. Department of Energy Office of Fossil Energy, National Energy Technology Laboratory, November 2004
- [4] Osamu Yamamoto, Solid oxide fuel cells: fundamental aspects and prospects, *Electrochimica Acta* 45 (2000) 2423–2435

*Design And Analysis Of Diesel Fueled Solid Oxide Fuel Cell System
Onboard Surface Ship*

- [5] Christoph Stiller, Design, Operation and Control Modeling of SOFC/GT Hybrid Systems, Doctoral Theses at NTNU, 2006:28
- [6] S. Singhal, K. Kendall (Eds.), High Temperature Solide Oxide Fuel Cells: Fundamentals, Design and Applications, Elsevier, 2003.
- [7] Inyong Kang, Joongmyeon Bae, Autothermal reforming study of diesel for fuel cell application, Journal of Power Sources 159 (2006) 1283–1290
- [8] U.S. Department of Defense, 2006, MIL-DTL-16884L, Detail Specification Fuel Naval Distillate, 23 October 2006
- [9] NATO Standardization Agreement (STANAG) Stanag No:1385 (Edition 3), Guide Specifications (Minimum Quality Standards) For Naval Distillate Fuels, 20 April 2006
- [10] Steinfeld G, Sanderson R, Ghezel-Ayagh H, Abens S, Cervi MC. Distillate fuel processing for marine fuel cell applications. AICHE spring 2000 meeting, 5–9 March 2000, Atlanta, GA, USA.
- [11] S. Katikaneni, C. Yuh, S. Abens, M. Farooque, 2002, The direct carbonate fuel cell technology: advances in multi-fuel processing and internal reforming, Catalysis Today 77, 99–106
- [12] Amphlett, J. C., Mann, R. F., Peppley, B.A., Roberge, P.R., Rodrigues, A., Salvador, J. P. (1998). “Simulation of a 250 kW Diesel Fuel Processor/ PEM Fuel Cell System.” International Journal of Hydrogen Energy. 71. 179-184
- [13] Çoban, M., TURHAN, Java 2 Programming Manual (In Turkish), ALFA Yayınevi, Ticarethane Sok no 41/1 34410 Cagaloglu, Istanbul, ISBN 975-316-631-1
- [14] S.Ahmed, M.Krumpelt, Hydrogen from hydrocarbon fuels for fuel cells, International Journal of Hydrogen Energy 26 (2001) 291-301
- [15] Sorell, G., Corrosion-and heat-resistant nickel alloys, Guidelines for selection and application, Nickel Development Institute Technical Series No:10086, 1998
- [16] Sunden, Bengt, High Temperature Heat Exchangers (HTHE), Proceedings of Fifth International Conference, Science, Engineering and Technology, September, 2005
- [17] International Maritime Organization, 1998, Annex VI of MARPOL 73/78 “Regulations for the Prevention of Air Pollution from Ships”, International Maritime Organization, London, UK
- [18] Corbett, James J. and Farrell, Alex, Mitigating Air Pollution Impacts of Passenger Ferries, Transportation Research Part D 7 (2002) 197-211
- [19] S. Krummricha, B. Tuinstra, G. Kraaij, J. Roes, H. Olgun, Diesel fuel processing for fuel cells—DESIRE, Journal of Power Sources 160 (2006) 500–504